

CAT INJECTOR INSTALLATION INFORMATION

Thank you for purchasing *ProDiesel* Product. Here are some informative tips to help you have the best replacement experience.

Remember the 5 F's

1. **Follow the manufacturer's instructions.**
2. **Flush the fuel system.**
3. **Filter - Replace the filter.**
4. **Free - Keep area Free from dirt and debris.**
5. **Failure to do these things will result in a poor result.**

IMPORTANT INFORMATION

- Before installing replacement injectors, it is good practice to confirm the root cause of the failure.
- If the failure can be attributed to a contaminated system such as metal from a failed high-pressure pump or poor fuel handling, the condition must be corrected, and the system flushed before installing and running the replacement injector(s).
- Do not remove the injector from its protective packaging until you are ready to install. This will reduce the likelihood of contamination or external damage.
- To ensure proper engine performance the unique trim code provided on the CD-ROM must be entered into the engine ECM.
- To prevent injector plunger spring failure, the fuel system should be primed before starting the engine.
- Deviating from these recommendations could result in premature failure of the replacement injector(s) and possibly void any warranties.

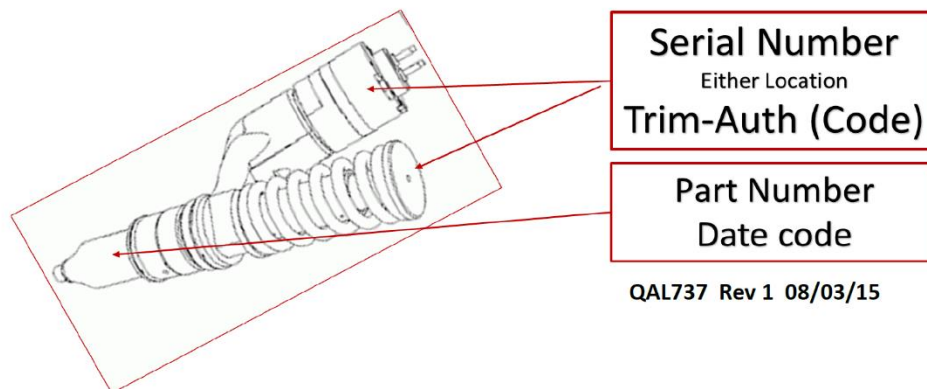

Please refer to the OEM Guides and Manuals for the Manufacturer's specifications and procedures.

ProDiesel's use of names or other descriptive symbols is for reference only and does not imply that any product is made by the O.E.M.